

# The RoboKnee: An Exoskeleton for Enhancing Strength and Endurance During Walking

Jerry E. Pratt  
Institute for Human and Machine Cognition  
www.ihmc.us  
jpratt@ihmc.us

Benjamin T. Krupp, Christopher J. Morse  
Yobotics, Inc.  
www.yobotics.com  
benkrupp@yobotics.com

Steven H. Collins  
University of Michigan  
shc@umich.edu

**Abstract**—Exoskeletons that enhance human strength, endurance, and speed while being transparent to the wearer are feasible. In order to be transparent, the exoskeleton must determine the user's intent, apply forces when and where appropriate, and present low impedance to the wearer.

We present a one degree of freedom exoskeleton called the RoboKnee which achieves a high level of transparency. User intent is determined through the knee joint angle and ground reaction forces. Torque is applied across the knee in order to allow the user's quadriceps muscles to relax. Low impedance is achieved through the use of Series Elastic Actuators.

The RoboKnee allows the wearer to climb stairs and perform deep knee bends while carrying a significant load in a backpack. The device provides most of the energy required to work against gravity while the user stays in control, deciding when and where to walk, as well as providing balance and control. Videos, photographs, and more information about the RoboKnee can be found at <http://www.yobotics.com>

*Keywords*—exoskeleton; Series Elastic Actuators; low impedance

## I. INTRODUCTION

Exoskeletons promise to someday be ubiquitous, enhancing people's strength, endurance, and speed in many activities. Recreational users will hike further, jump higher, and run faster. Rescue workers and firefighters will climb buildings and run up skyscraper stairwells without tiring. Soldiers will be able to run at high speeds with heavy equipment loads. Persons with walking disabilities will be able to work and play in environments that were traditionally off-limits.

In order to be useful and accepted by people, these exoskeletons must achieve certain capabilities and performance characteristics including the following:

- **Human Performance Enhancement:** The exoskeleton should increase the wearer's strength, endurance, and/or speed enabling them to perform tasks that they previously could not perform.

- **Low Impedance:** The exoskeleton should not impede the user's natural motion.
- **Natural Interface:** The exoskeleton should provide a natural, intuitive, transparent interface such that the user feels as if the exoskeleton is a true extension of his/her body rather than something that the user is driving.
- **Long Life:** The exoskeleton should have sufficient duration of use between energy system recharge and a quick and easy recharging method.
- **Comfortable:** The exoskeleton should be comfortable and safe to wear and easy to don and doff.



Figure 1. RoboKnee (on right leg only) providing power required to climb stairs at City Hall, Boston on August 24, 2001. The backpack contains the computer system and 4 kilograms of Nickel-Metal-Hydride batteries, enough to power the system for 30-60 minutes of heavy usage.

As with robots, it is difficult to define what an exoskeleton is. To some extent, any device that a user can wear or drive is

an exoskeleton. When one drives a car, there is a feeling that the car has become an extension of the user’s body and that the driver and the car are one inseparable entity. However, with an automobile, there are a few features that distinguish it from an ideal exoskeleton. First the car’s interface is not transparent. There is a clear steering wheel, gas pedal, and brake pedal, each of which mostly transmits information one way – from the user to the mechanism. These mechanisms do not have a correspondence with natural locomotion and thus must be learned. Additionally, a car impedes a user’s natural motion, almost completely immobilizing the driver’s body.

Although a car is exceptionally useful, an ideal exoskeleton would be completely transparent to the user, presenting the illusion that the wearer simply had stronger, faster, or more accurate limbs. To achieve this transparency, the exoskeleton must successfully perform the following functions:

- Determine the user’s intent.
- Apply forces when and where appropriate.
- Present low impedance, i.e. “get out of the way”.

While other exoskeletons [5,6,7,9-16,19-23,25-27] have achieved the first two criteria to some extent, presenting low impedance has been a challenge. In this paper we introduce the RoboKnee, a prototype exoskeleton that presents low impedance to the wearer and has a natural interface. Due to low energy density of batteries, the RoboKnee does not yet achieve the long life requirement. While it is very comfortable to use, the current implementation is somewhat difficult to don and doff. In this paper we describe the design, actuation, and control of the RoboKnee.

## II. ROBOKNEE DESIGN

The RoboKnee mechanism, shown in Figure 2, is a fairly straightforward design, utilizing an off-the-shelf knee brace. Additional structural pieces are added to the knee brace to extend it and to provide attachment points for the actuator. A linear Series Elastic Actuator is connected between the upper and lower portions of the knee brace so that it provides a torque about the knee.

Two load cells are located in rigid-bottom bicycle shoes such that the entire load between the wearer’s foot and the ground passes through the load cells. With two load cells the vertical ground reaction force and the fore-aft center of pressure can be measured. However, the sideways forces and the angle of the force vector with respect to the ground cannot be measured. In all of the control algorithms, we assume that the force is purely vertical. The knee angle is determined from the actuator stroke, measured with a linear encoder on the Series Elastic Actuator. This signal is differentiated in software to produce the joint velocity.

An aJile aJ-PC104 board that runs native Java is used to control the system. A Diamond Systems MM1612 add-on boards is used for D/A conversion to produce the desired force signal. This signal is input to an analog PD controller that controls the Series Elastic Actuator force. A model 5912 PC-104 Encoder Interface board from ACS-Tech80 is used to read the linear encoder signal.

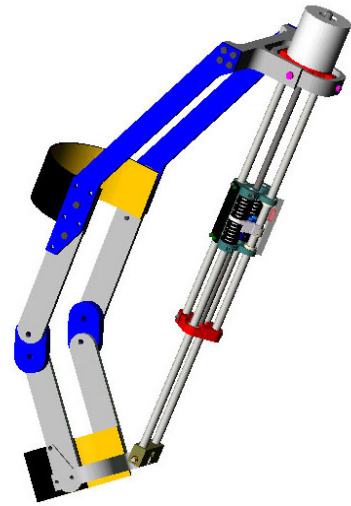

Figure 2. RoboKnee design showing knee brace and Series Elastic Actuator. The joint position and velocity are deduced based on the actuator stroke and linear velocity, measured with a linear encoder. Not shown are the Velcro straps and the lower connection piece.

## III. LOW IMPEDANCE SERIES ELASTIC ACTUATORS

Presenting low impedance is beneficial in many robotic applications, particularly those involving contact with an unknown environment, or attachment to a user. The lack of low impedance actuation has hindered many attempts at such applications.

To achieve low impedance and high force fidelity with the RoboKnee, we use Series Elastic Actuators [17][18]. In Series Elastic Actuators, stiff load cells (which are delicate, expensive, and induce chatter) are replaced with a significantly compliant elastic element (which is robust, inexpensive, and stable). Figure 3 shows the architecture of Series Elastic Actuators. A spring is intentionally placed between the motor and the load. A sensor measures the spring deflection which is proportional to the force on the load. This force is compared to the desired force and the error sent to a control system. Note that Series Elastic Actuators are topologically similar to any motion actuator with a load sensor and closed loop control system.

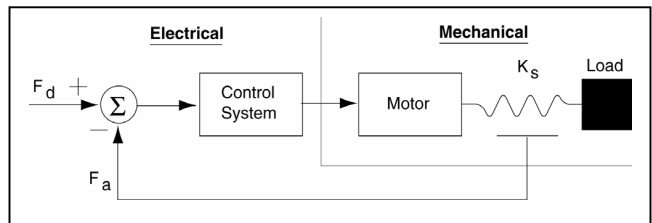

Figure 3. Series Elastic Actuator Block Diagram. The desired force is compared to the actual measured force to produce an error signal. The error signal is passed through a control system, typically a PD controller that produces a desired current on the motor. A spring is placed after the motor transmission and before the load. A linear potentiometer measures the spring deflection and converts that signal to spring force.

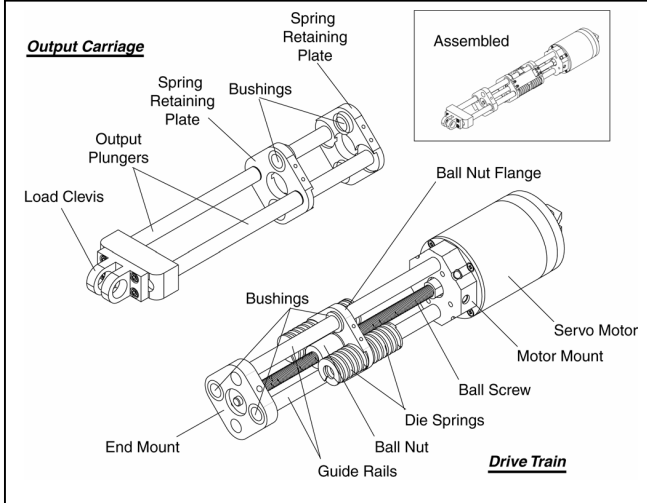

Figure 4. Exploded view of a Series Elastic Actuator. A brushless DC servo motor drives a ballscrew. The ball nut flange pushes against 4 die compression springs. These springs then push against 2 spring retaining plates are clamped to two output plungers. A linear potentiometer measures the spring deflection.

In contrast to the load cell method, Series Elasticity introduces significant compliance between the actuator’s output and the load, allowing for greatly increased control gains. Consider, as above, the case of a compliant spring between a linear actuator and rigid load. A moderate linear movement will generate a very small force reading. Thus, closed loop control gains can be very high while still insuring the absence of chatter and presence of stability. Increased control gains greatly reduce impedance and reduce the effects of stiction to give the actuators clean force output. Because high-impedance and high-stiction components such as gear trains or hydraulic cylinders are tolerable, the cost and weight can be reduced by allowing the use of smaller, low precision actuator components and replacing expensive load cells with simple springs and position transducers (encoders, potentiometers). These improvements can be achieved in both electric and hydraulic actuation domains.

Figure 4 shows an exploded view of the Series Elastic Actuators that are used in the RoboKnee. The actuator consists of two subassemblies: a drive train subassembly and an output carriage subassembly. When assembled, the output carriage subassembly, a rigid structure, is coupled to the drive train subassembly through the die compression springs. Spring retaining plates firmly sandwich the die springs and ball nut flange. Guide rails pass through bushings in the ball nut flange, forcing the ball nut into linear motion when the ball screw spins. The guide rails also pass through bushings in the spring retaining plates, forcing the entire output carriage subassembly to follow the linear motion of the ball nut.

During operation, the servomotor directly drives the ball screw, converting rotary motion to linear motion of the ball nut. The ball nut flange pushes on four die compression springs, which push on the corresponding spring retaining plate. Spring retaining plates are rigidly attached to output plungers, which

are directly connected to the load clevis. The force on the load is calculated by measuring the compression of the die springs with a linear potentiometer spanning the spring retaining plates. A proportional-derivative (PD) control loop is used to control the actual force on the load.

TABLE I. ROBOKNEE SERIES ELASTIC ACTUATOR SPECIFICATIONS

Parameter	English Value	Metric Value
Weight	2.5 lbs	1.13 kg
Stroke	Up to 12 in.	30.5 cm
Diameter	2.3 in.	5.8 cm
Length	Stroke + 6in.	Stroke + 15 cm
Maximum Speed	11 in/sec	28 cm/sec
Continuous Force	127 lbs	565 N
Continuous Power	0.22 HP	164 W
Intermittent Force	300 lbs	1330 N
Intermittent Power	0.85 HP	634 W
Minimum Resolvable Force	< 1 lb.	< 4.4 N
Dynamic Range	> 300	> 300
Cont Power to Weight	0.088 HP/lb	145 W/kg
Max Power to Weight	0.34 HP/lb	561 W/kg
Small Force Bandwidth	35 Hz	35 Hz
Large Force Bandwidth	7.5 Hz	7.5 Hz
Operating Voltage	24-48 Volts	24-48 Volts
Maximum Current	20 Amps	20 Amps

The specifications of the Series Elastic Actuator used on the RoboKnee are listed in Table I. The actuators can supply up to 1330 N (300 lbs) with a minimum resolvable force of less than 4.4 N (1 lb), resulting in a dynamic range of over 300. The small force bandwidth is 35 Hz. Large forces, near the maximum intermittent force, can be achieved at up to 7.5 Hz bandwidth. The maximum power of the actuator is 634 W, with a continuous power rating of 164 W.

The low impedance, high force-fidelity, and good bandwidth of these actuators enabled the RoboKnee control algorithm, which relies on a high performance force source.

#### IV. ROBOKNEE CONTROL ALGORITHM

The current implementation of the RoboKnee control algorithm is very simple. The device is programmed to perform force amplification in such a way that the force required by the quadriceps muscle is significantly less than what would be required without the device.

We achieve this goal through positive feedback force amplification. The ground reaction force on the foot is measured and used to compute the torque that would be on the knee in a static situation:

$$\vec{\tau} = \vec{R} \times \vec{F}, \quad (1)$$

where  $\vec{F}$  is the ground reaction force vector,  $\vec{R}$  is the vector from the ground reaction force to the knee joint, and  $\vec{\tau}$

is the estimated knee torque. Note that all three of these quantities are estimates due to the lack of measured information. We know the magnitude and point of application of the force vector, but we do not know its direction since we are only using two single axis load cells. Instead, we assume that the force vector is purely vertical. We do not know the exact vector from the ground reaction force to the knee joint since we are not measuring the ankle joint angle. Instead we assume that the hip is directly over the heel and thus  $\bar{R}$  is a function of the knee angle and the thigh and shank lengths.

Once we have an estimated knee torque, the required actuator force to produce that knee torque can be easily computed geometrically. An amplification factor,  $\alpha$ , is then used to determine how much of the force the exoskeleton should provide. If  $\alpha$  is one, then the exoskeleton provides the full force. If  $\alpha$  is zero, then the exoskeleton provides no force.

Note that there are many simplifying assumptions used in calculating the required actuator force. Due to these assumptions, the force produced by the exoskeleton will be off, typically up to  $\pm 20\%$ , from the exact force required to allow the quadriceps muscles to fully relax. However, this is completely acceptable for two reasons. First, augmenting the wearer by a small amount can often lead to enormous performance gains. For example, the wearer may be performing an activity just stressful enough that his/her muscles are generating power anaerobically. A very small muscle augmentation may be all that is required to move the muscle power generation from being anaerobic to aerobic, thereby extending the endurance of the user from a few minutes to a few hours. Similarly, a user that can only lift 50 kilograms can lift a 60 kg object with only a 10 kg boost.

Secondly, the user will compensate, quite rapidly, for any "error" that the exoskeleton produces. In fact, if the amplification factor,  $\alpha$ , is set to below zero, then the device will work against the user making the task more difficult. If it is set above one, then the exoskeleton will assist too much, requiring the user to work against the device to perform the task. In both cases, as long as the user is still physically capable, he/she can perform the task despite the resistance provided by the exoskeleton. In fact, this may be desirable in some cases in which the exoskeleton acts as an exercise machine or rehabilitation device.

## V. ROBOKNEE EVALUATION

The RoboKnee successfully enhances human performance while not impeding the user's natural walking gait. It has a natural interface and is safe and comfortable. However, it only has a limited lifetime between battery recharges.

### A. Human Performance Enhancement

The RoboKnee demonstrated improved strength and endurance when walking up stairs, when carrying heavy loads, and when performing deep knee bends. In the clearest demonstration, a user was able to do one-legged deep knee bends with a 60 kg backpack load filled with sand without getting tired. Without the assistance of the RoboKnee, the

same user could only do two to three one-legged knee bends with this weight, and on the order of 10 when using two legs.

While the RoboKnee enhances strength and endurance, it was not designed for enhancing the user's speed and in fact restricts the user from running.

### B. Low Impedance

The RoboKnee presents very low impedance to the wearer at speeds up to approximately 2.5 m/s, i.e. casual walking speed. The Series Elastic Actuator provides very little resistance and the components are relatively light (less than 3 kg total, including the knee brace, actuator, and straps).

### C. Natural Interface

To use the RoboKnee, the wearer simply puts it on and starts walking. There are no control panels, switches, joysticks, displays, or other explicit user interfaces. For walking, climbing up stairs, and performing deep knee bends, there is zero required training time. Walking down stairs quickly, however, requires a little conscious effort. This effort is required as the RoboKnee effectively cancels gravity. Without gravity assisting the step down, the user must adapt a new coordination strategy, using muscle groups differently than they would normally use when going down stairs. After a couple minutes of practice, however, the user successfully adapts to the motion.

### D. Long Life

The RoboKnee does not meet the requirement of a long lifetime between battery recharges as it only achieves 30-60 minutes of heavy use with 4 kg of nickel-metal-hydride batteries. This range would be doubled with the use of silver-zinc batteries, resulting in a time between charges of 1 to 2 hours. This may be sufficient for certain uses, but not long enough for general acceptance.

### E. Comfortable and Safe

The RoboKnee is comfortable to wear and does not produce any bruises or sores on the user. The forces are distributed over at least 10 square centimeters at each attachment point. Since gait is periodic, the forces on the body are periodic. Humans can support large forces on their skin as long as they are intermittent. Therefore, the RoboKnee presents no danger of pressure sores.

The RoboKnee does rely on the bones of the wearer to transmit forces to the ground, including any additional loads that the RoboKnee enables. Therefore, it is only safe to use the RoboKnee for performing tasks and carrying loads that are safe on one's bones without the use of the RoboKnee. In other words, while the RoboKnee augments muscle strength, it does not augment bone strength. Therefore, we limited loads to 60 kg for healthy individuals wearing the RoboKnee.

In its current implementation, the RoboKnee takes about 10 minutes to don and doff, which is unacceptable for many applications. With simple design changes, we estimate that we could reduce that time to less than 3 minutes.

The largest drawback to comfort for the RoboKnee is that the user cannot sit when wearing it, as the actuator is placed

behind the user. Moving the actuator to the side of the leg may remedy this drawback.

## VI. NEXT STEPS

### A. Addition of the Hip and Ankle Joints

The RoboKnee was built during a feasibility study to demonstrate that exoskeletons can enhance human performance, while not impeding the wearer's natural movements. In its current implementation it has potential applications in recreational hiking, firefighting, and search and rescue. However, some applications will require augmentation of the ankle and/or hip in addition to the knee. These joints present a more demanding design challenge than the knee as they have more explicit degrees of freedom. They also require more sophisticated user intent detection than what is currently used on the RoboKnee.

### B. Advanced User Intent Detection

The RoboKnee uses a very simple method for user intent detection. It simply determines the desired knee torque based on the measured ground reaction forces. This is sufficient for enhancing knee strength during walking, climbing stairs and slopes, and performing deep-knee lifts. However, controlling actuators at the other joints requires more advanced user intent detection.

The hip provides power during walking mostly during the beginning and end of the swing phase. Therefore, augmenting the hip without directly sensing nerves may require keeping track of the walking state and predicting the beginning and end of swing. Likewise, the ankle provides power during walking mostly during the end of stance or "toe-off". Augmenting the ankle may also require tracking the state of walking.

We are confident, however, that simple control algorithms that rely on a small number of sensors can be developed for both the ankle and the hip.

## VII. GIANT LEAPS

While the RoboKnee successfully provides performance augmentation to the wearer, there are many hurdles that must be overcome before it, and devices like it, will be widely used and accepted. Its two most significant drawbacks are bulk and short lifetime between energy recharge. These two drawbacks highlight the need for more compact actuators and better energy sources.

### A. More Compact Actuators

To date the only actuation technologies that have proven sufficient for powering an exoskeleton are electromagnetic, hydraulic, and pneumatic. Each of these technologies uses fairly bulky, rigid, components that are inherently high impedance. Converting these components to low impedance Series Elastic Actuators requires springs and other bulky rigid components. The result is an exoskeleton that significantly increases the volume of the wearer, restricting certain activities. In the case of the RoboKnee, the user cannot sit down when wearing the device.

There are many studies underway to develop "artificial muscle". Many of these studies have resulted in actuation

technologies with impressive power and force densities. However, actuation technologies with high power and force densities, *as well as low inherent impedance* have been elusive.

Real muscle gets its low impedance since each actin-myosin pair is either engaged and force producing or *completely disengaged*. Perhaps artificial muscle technology will need to operate on this physical principle of muscle in order to be useful for exoskeletons and other robotic devices. One can envision an artificial muscle that on the micro or nano scale consists of millions to billions of tiny latching devices, each with low impedance when producing force, and zero impedance when detached. Such actuators would also greatly reduce energy requirements for low-impedance motions.

### B. Better Energy Sources

The RoboKnee uses nickel-metal-hydride batteries with an energy density of approximately 100 Watt-hours per kilogram. Four kilograms of these batteries provide a running time of between 30 and 60 minutes of heavy use. More exotic batteries, such as silver-zinc, could double that time. However, many activities will require tens of hours of heavy use between recharge. While fuel cells have the potential to provide the required energy densities, they still have fairly low power densities. Gasoline powered systems do have the required power and energy densities, but they can only be used outdoors and produce too much noise for some applications.

### C. Direct Nervous System Connection

While there are many algorithmic methods for determining user intent, an exoskeleton that is truly an extension of one's body, and feels as though it is will require more direct connection to the user's nervous system. To be widely accepted, this connection must be non-invasive, easy to attach, and comfortable. Non-invasive sensing of commands to muscles may be the most promising method. Kawamoto and Sankai [10, 11, 12] are currently investigating EMG based commands. With more advances this approach may some day result in exoskeletons that effectively augment the wearer's muscle mass with few detrimental effects.

## VIII. CONCLUSIONS

Exoskeletons that enhance human strength, endurance, and speed are feasible and will someday be ubiquitous. Hikers who wish to go further with less effort will be able to stop at a sports store and buy an undergarment resembling a thick version of today's Spandex. To the casual observer it will be difficult to see any difference and to the wearer it will seem as though they simply have more muscle than before.

The RoboKnee demonstrates the feasibility of this technology and shows that a simple device with a simple control algorithm can significantly enhance one's capabilities. However, the RoboKnee is still too bulky and has too short of a lifetime between battery recharge to be widely accepted. Advances in actuation technologies and energy storage technologies will need to occur before exoskeletons see widespread use.

## IX. ACKNOWLEDGEMENTS

The RoboKnee was funded by a grant from Powered Prosthetics, Inc.

## REFERENCES

- [1] Bar-Cohen, Y. and C. Breazeal, *Biologically Inspired Intelligent Robots*. Bellingham, WA: SPIE – The International Society for Optical Engineering, 2003.
- [2] Blaya, J., “Force controllable ankle foot orthosis to assist drop-foot gait.”, *Mech. Eng. MS Thesis*, MIT 2002.
- [3] Danov, V. A., V. S. Gurfinkel, and V. G. Ostapchuk. 1980. Modeling of the anthropomorphic control of the process of foot transfer of an exoskeleton for paraplegics. *Engineering Cybernetics* 18.
- [4] Brown, P., D. Jones, S. K. Singh, and J. M. Rosen. 1993. The exoskeleton glove for control of paralyzed hands. *Proceedings IEEE International Conference on Robotics and Automation* 642-647.
- [5] Canales, L. and M. M. Stanisic. 1990. Preliminary design of an exoskeleton shoulder joint without dead positions. *IEEE International Conference on Systems Engineering* 94-96.
- [6] Colombo, G., M. Jorg, and V. Dietz. 2000. Driven gait orthosis to do locomotor training of paraplegic patients. *Proceedings of the 22nd Annual International Conference of the IEEE Engineering in Medicine and Biology Society* 3159-3163.
- [7] Grundmann, J. and A. Seireg. 1977. Computer control of multi-task exoskeleton for paraplegics. *Second CISM/IFTOMM International Symposium on the Theory and Practice of Robots and Manipulators* 233-240.
- [8] Hollerbach, J. M. and S. C. Jacobsen. 1995. Haptic interfaces for teleoperation and virtual environments. *First Workshop on Simulation and Interaction in Virtual Environments I-VI*.
- [9] Johnson, D. C., D. W. Repperger, and G. Thompson. 1996. Development of a mobility assist for the paralyzed, amputee, and spastic patient. *Proceedings of the 1996 Fifteenth Southern Biomedical Engineering Conference* 67-70.
- [10] Kawamoto, H. and Y. Sankai. 2001. EMG-based hybrid assistive leg for walking aid using feedforward controller. *ICCAS 2002. International Conference on Control, Automation and Systems* 190-193.
- [11] Kawamoto, H. and Y. Sankai. 2002a. Comfortable power assist control method for walking aid by HAL-3. *2002 IEEE International Conference on Systems, Man and Cybernetics. Conference*.
- [12] Kawamoto, H. and Y. Sankai. 2002b. Power assist system HAL-3 for gait disorder person. *Computers Helping People with Special Needs 8th International Conference, ICCHP 2002. Proceedings (Lecture Notes in Computer Science Vol. 2398)* 196-203.
- [13] Kazerooni, H. 1996. The human power amplifier technology at the University of California, Berkeley. *Robotics and Autonomous Systems* 19: 179-187.
- [14] Kosso, E. V. 1973. A minimum energy exoskeleton. *1973 Carnahan Conference on Electronic Prosthetics* 86-89.
- [15] Lee, S., A. Agah, and G. Bekey. 1990. IROS: an intelligent rehabilitative orthotic system for cerebrovascular accident. *1990 IEEE International Conference on Systems, Man and Cybernetics Conference Proceedings* 815-819.
- [16] Petrofsky, J. S., C. A. Phillips, R. Douglas, and P. Larson. 1985. Integration of orthosis with computer-controlled movement. *Proceedings of the IEEE 1985 National Aerospace and Electronics Conference NAECON 1985* 1012-1018.
- [17] Pratt, J., B. Krupp, and C. Morse. 2002. “Series elastic actuators for high fidelity force control,” *Industrial Robot: An International Journal*, vol.29, no. 3, 2002, pp.234-241.
- [18] Pratt, G. and M. Williamson. 1995, “Series Elastic Actuators”, *Proceedings of IEEE International Conference on Intelligent Robots and Systems (IROS '95)*.
- [19] Remis, S. J. 1990. Design of an exoskeleton with kinesthetic feedback: Lessons learned. *IEEE International Conference on Systems Engineering* 109-112.
- [20] Repperger, D. W., B. O. Hill, C. Hasser, M. Roark, and C. A. Phillips. 1996. Human tracking studies involving an actively powered, augmented exoskeleton. *Proceedings of the 1996 Fifteenth Southern Biomedical Engineering Conference* 28-31.
- [21] Rosen, J., M. Brand, M. B. Fuchs, and M. Arcan. 2001. A myosignal-based powered exoskeleton system. *IEEE Transactions on Systems, Man & Cybernetics, Part A (Systems & Humans)* 31: 210-222.
- [22] Rosen, J., M. B. Fuchs, and M. Arcan. 1999. Performances of Hill-type and neural network muscle models-toward a myosignal-based exoskeleton. *Computers and Biomedical Research* 32: 415-439.
- [23] Rosheim, M. E. 1990. Man-amplifying exoskeleton. *Proceedings of the SPIE - The International Society for Optical Engineering* 1195: 402-411.
- [24] Shields, B. L., J. A. Main, S. W. Peterson, and A. M. Strauss. 1997. An anthropomorphic hand exoskeleton to prevent astronaut hand fatigue during extravehicular activities. *IEEE Transactions on Systems, Man & Cybernetics, Part A (Systems & Humans)* 27: 668-673.
- [25] Tsagarakis, N., D. G. Caldwell, and G. A. Medrano-Cerda. 1999. A 7 DOF pneumatic muscle actuator (pMA) powered exoskeleton. *8th IEEE International Workshop on Robot and Human Interaction. RO-MAN '99* 327-333.
- [26] Umetani, Y., Y. Yamada, T. Morizono, T. Yoshida, and S. Aoki. 1999. "Skil Mate" wearable exoskeleton robot. *IEEE SMC'99 Conference Proceedings. 1999 IEEE International Conference on Systems, Man, and Cybernetics* 984-988.
- [27] Vukobratovic, M., D. Hristic, and Z. Stojiljkovic. 1974. Development of active anthropomorphic exoskeletons. *Medical and Biological Engineering* 12: 66-80.
- [28] Wilkenfeld, A., “An auto-adaptive external knee prosthesis”, *PhD. Thesis*, MIT, 2000.